

GRIP HEATER

Accessory Name	Parts Number	Application Model	Issue Date	Publication No.	FRT
GRIP HEATER	08T70-MLC-D00	XL750	2023.1	MII	0.7 H

Introduction

ALL INFORMATION, ILLUSTRATIONS, DIRECTIONS AND SPECIFICATIONS INCLUDED IN THIS PUBLICATION ARE BASED ON THE LATEST PRODUCT INFORMATION AVAILABLE AT THE TIME OF APPROVAL FOR PRINTING. Honda Motor Co., Ltd. RESERVES THE RIGHT TO MAKE CHANGES AT ANY TIME WITHOUT NOTICE AND WITHOUT INCURRING ANY OBLIGATION WHATSOEVER. NO PART OF THIS PUBLICATION MAY BE REPRODUCED WITHOUT WRITTEN PERMISSION. THIS MANUAL IS WRITTEN FOR PERSONS WHO HAVE ACQUIRED BASIC KNOWLEDGE OF MAINTENANCE ON Honda MOTORCYCLES, MOTOR SCOOTERS OR ATVS.

Honda Dealer:







Please give a copy of these instructions to your customer.

Customer:

Because it requires specialized knowledge and special tools and equipment, it is recommended to install it at a dealer with qualified automobile maintenance.

How To Read These Symbols

Your safety, and the safety of others, is very important. To help you make informed decisions we have provided safety messages and other information throughout this manual.

-  **WARNING** You CAN be KILLED or SERIOUSLY HURT if you don't follow instructions.
-  **CAUTION** You CAN be HURT if you don't follow instructions.
-  **NOTICE** The purpose of this message is to help prevent damage to your vehicle, other property, or the environment.
-  **NOTE** Things you want to know, things that are useful to know.
-  Follow the instructions of the Service Manual.
-  Follow the other symbol instructions of the "Installation Instructions BASIC".

Instruction Other Symbols

The symbols used throughout this instructions show specific service procedures. Refer to "Installation Instructions BASIC" for description of each symbol.

INFORMATION

WARNING

- For secure adhesion of the grip heaters use the recommended adhesive agent (Honda Bond A) or equivalent.
- Be sure to open and close the throttle to check for smooth operation after installation of the right heated grip.

CAUTION

- To prevent burns, allow the engine, exhaust system, radiator, etc., to cool before installing the accessory.

NOTICE

- *Take care not to damage the painted surfaces of the motorcycle.*
- *Do not place magnetic field sensitive objects or magnets around the APS unit.*

NOTE:

- Remove the right grip as instructed in the motorcycle's Service Manual.
- Reinstall the removed parts on the motorcycle and make sure that wires and harnesses are not pinched.
- Disconnect the negative (-) cable from the battery before installing this accessory.
- Trim the excess ends off the wire ties after attaching them to the wire harnesses. Do not allow the cut part of the wire tie to interfere with another harness or brake hose.
- After reconnecting the battery, refer to the motorcycle Owner's Manual and set the meter.
- Move the handlebar right to left and check that the harnesses are not pinched by the neighboring components and that they are not too tight.
- After this accessory installation, check the lights (e.g. right/left turn signal lights and brake lights) for proper operation.
- Save all removed parts unless otherwise indicated.

PARTS LIST

When the instruction manual and installation instructions are included in this kit, be sure to give them to the customer.

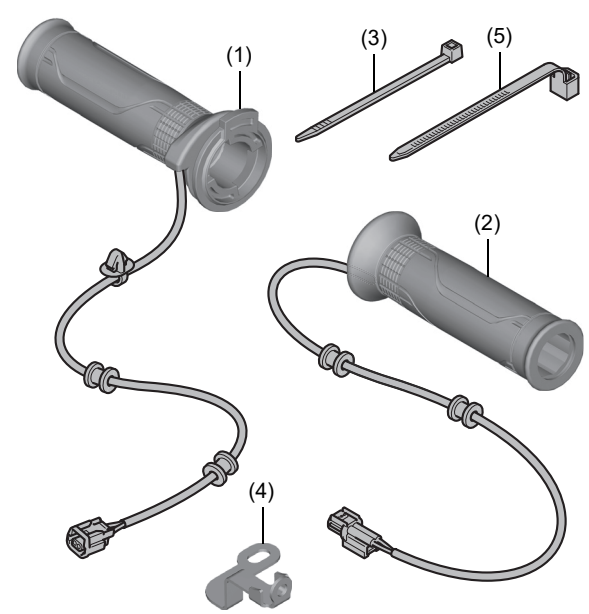
Component	No.	Parts Name	Qty	Parts No.
	(1)	Right heater	1	08T01-MLC-D00
	(2)	Left heater	1	08T00-MLC-305
	(3)	3.55 x 140* mm wire tie	7	35701-MG9-950
	(4)	Clamper	1	35135-MJM-D60
	(5)	7 x 165 mm wire tie	2	90651-KV6-003
* : Includes band tie length				

SYSTEM DIAGRAM

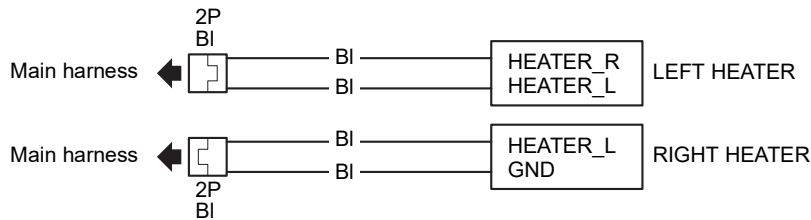

Identify wire colors:
BI: Black

TORQUE INFORMATION

Refer to the Service Manual for the torque values including standard torque of the removed parts. (🔧)

INSTALLATION

1. Refer to the Service Manual for motorcycle, remove the motorcycle parts as shown, and disconnect the negative (-) cable from the battery. (📖)

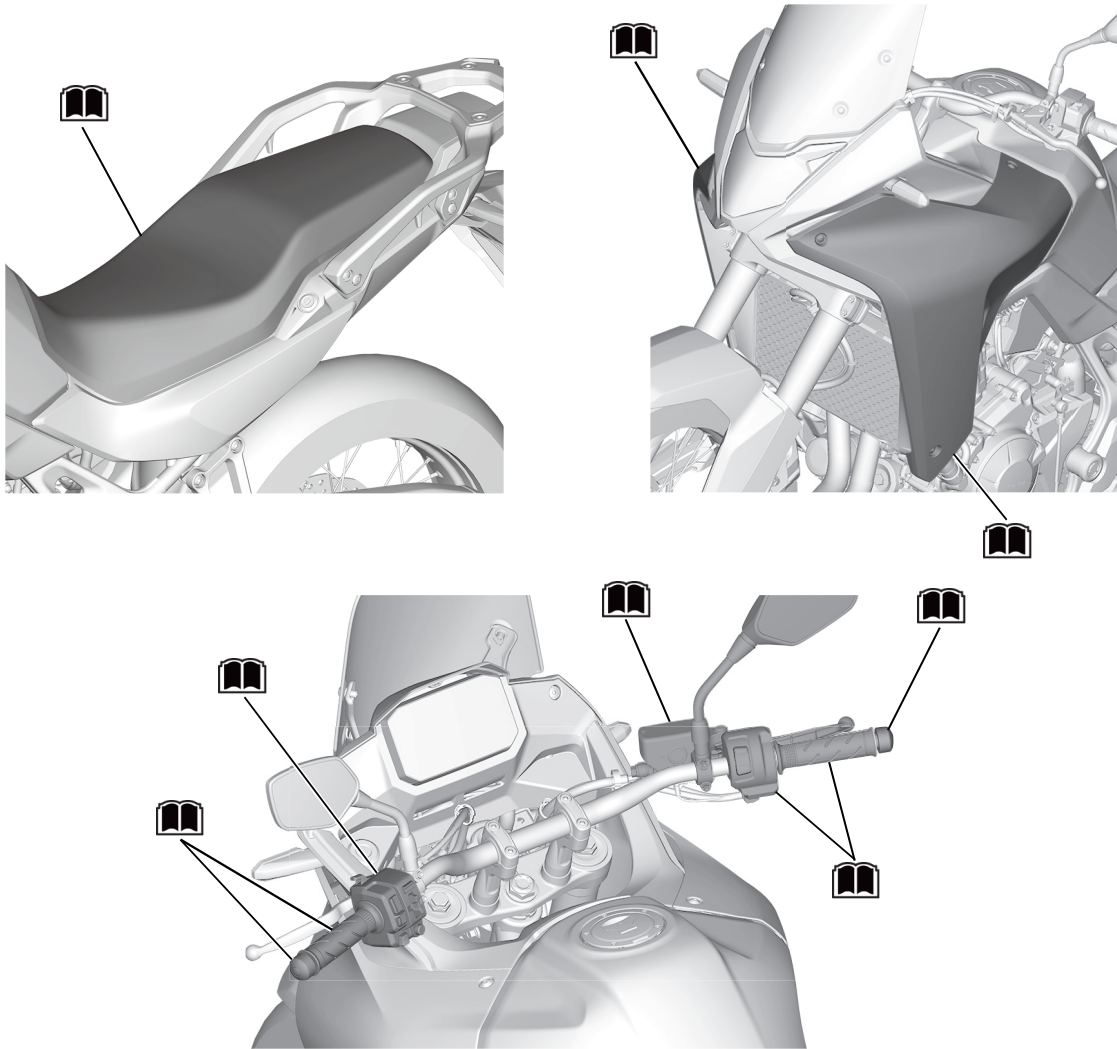

INSTALLATION IMAGE



2. Bundle the harness as shown.

<LEFT SIDE>

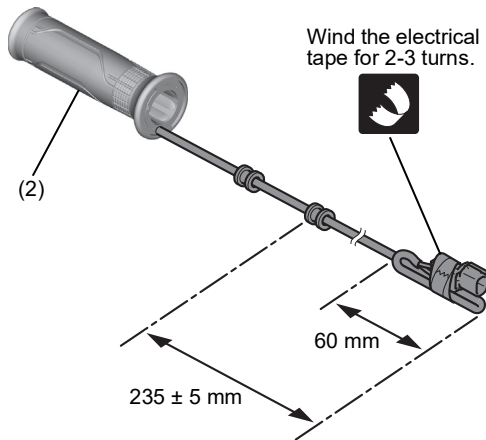

<RIGHT SIDE>

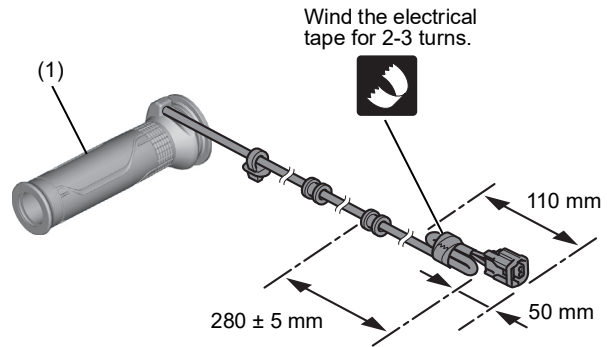

3. Install as shown.

<RIGHT SIDE>

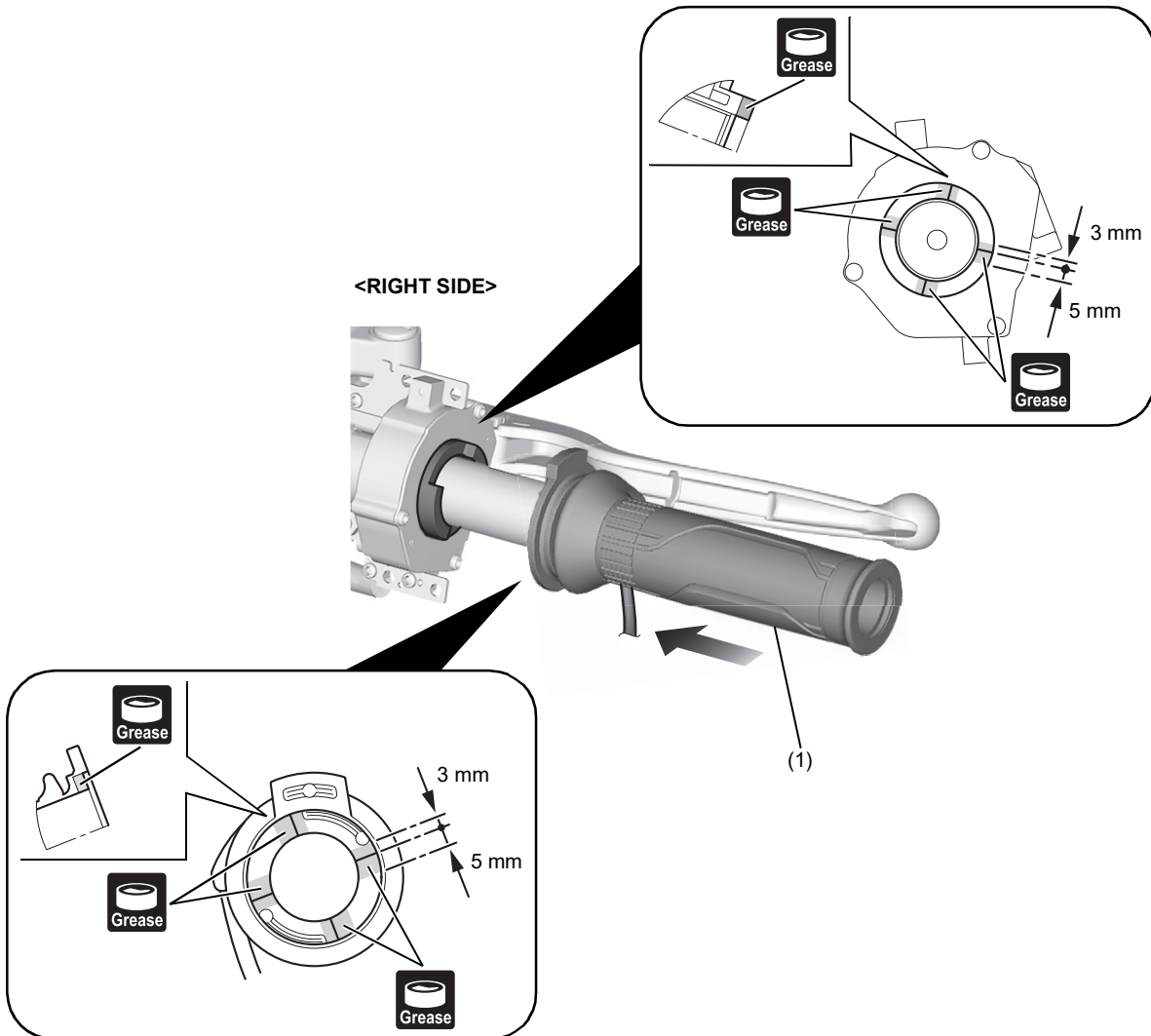

4. Install the right handle switch in the reverse order of removal.

5. Install as shown.

<RIGHT SIDE>

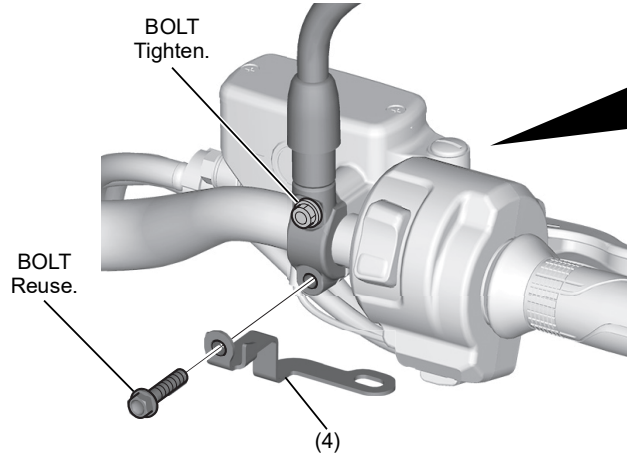

Tighten the upper bolt first, then tighten the lower bolt.

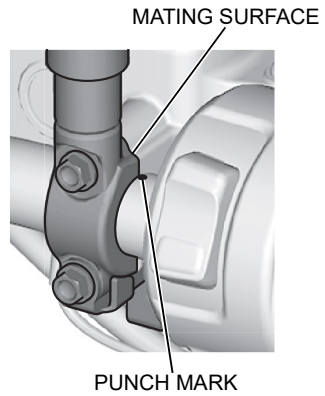

6. Route and connect the harness as shown.
 • Cut off the excess end of the wire tie (3), leaving a maximum of 5 mm.

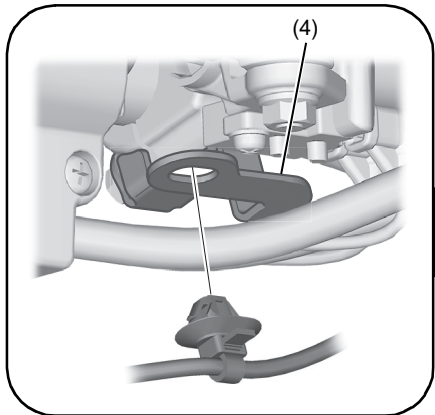
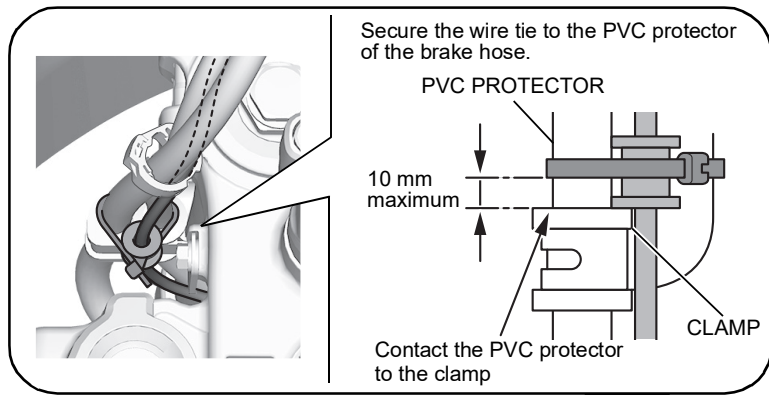

<RIGHT SIDE>

MOTORCYCLE'S WIRE TIE

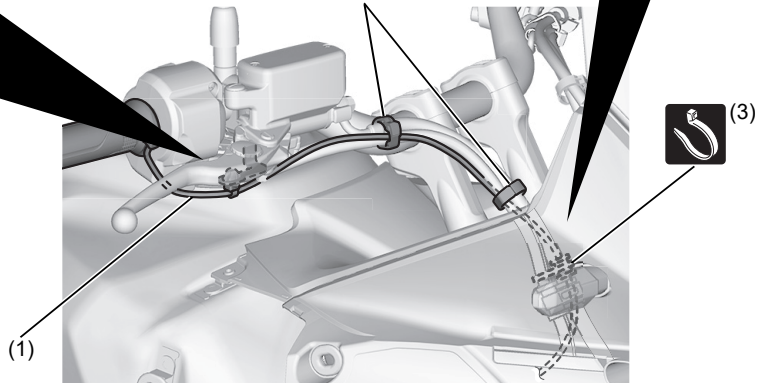

7. Route and connect the harness as shown.
- Cut off the excess ends of the wire ties (3), leaving a maximum of 5 mm.
 - Confirm that the grip heater harness does not contact the fuel tank.

<RIGHT SIDE>

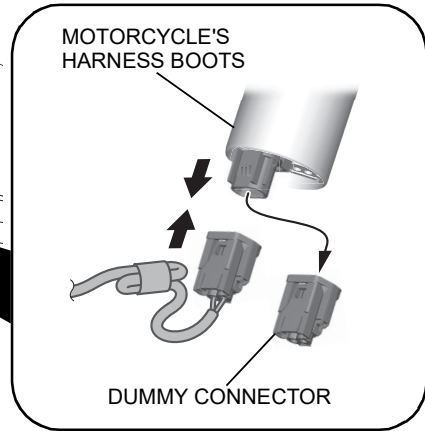
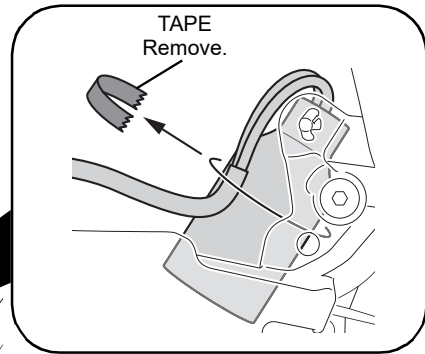
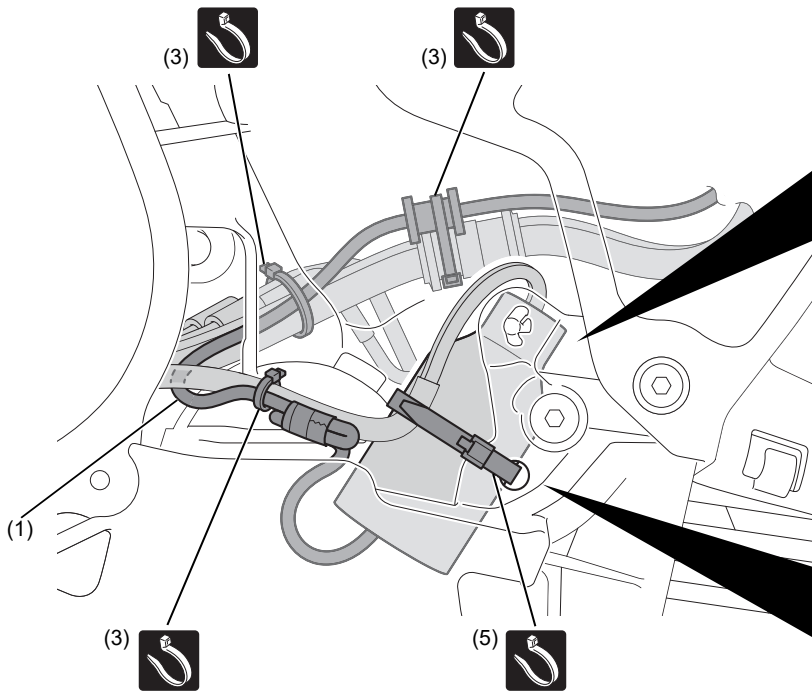

8. Install as shown.

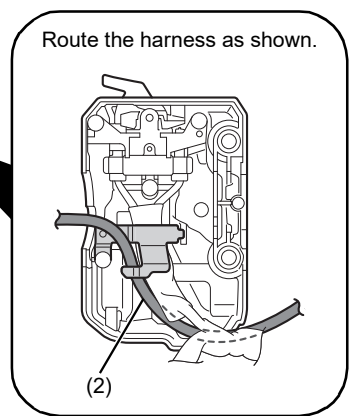
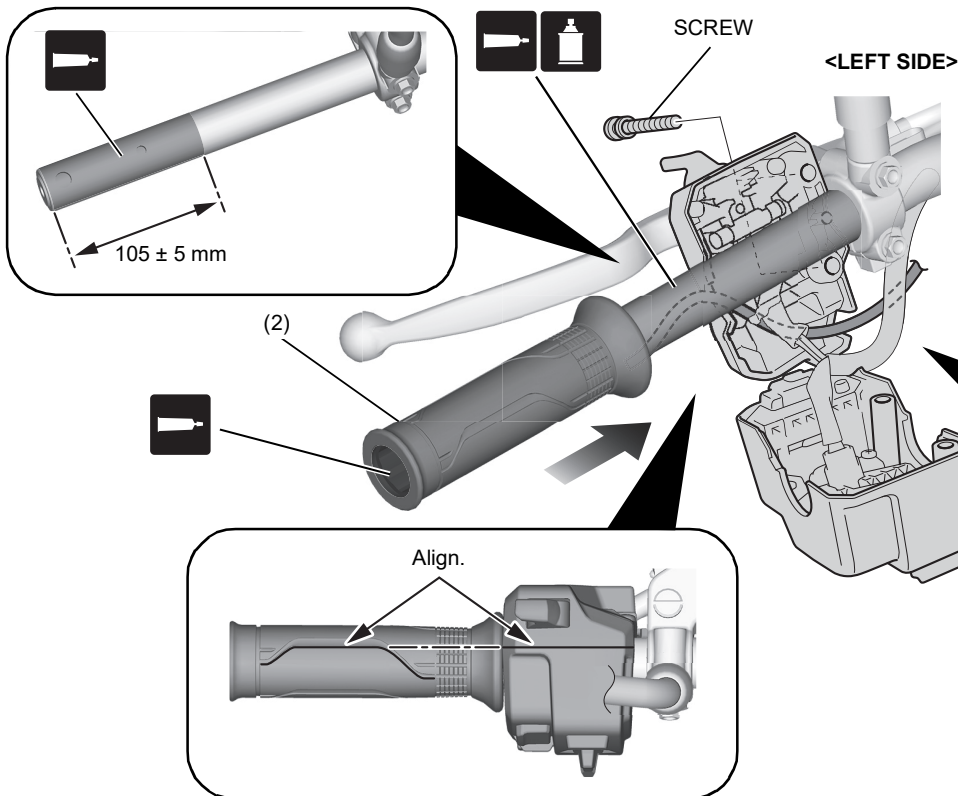

9. Route and connect the harness as shown.
- Cut off the excess end of the wire tie (3), leaving a maximum of 5 mm.

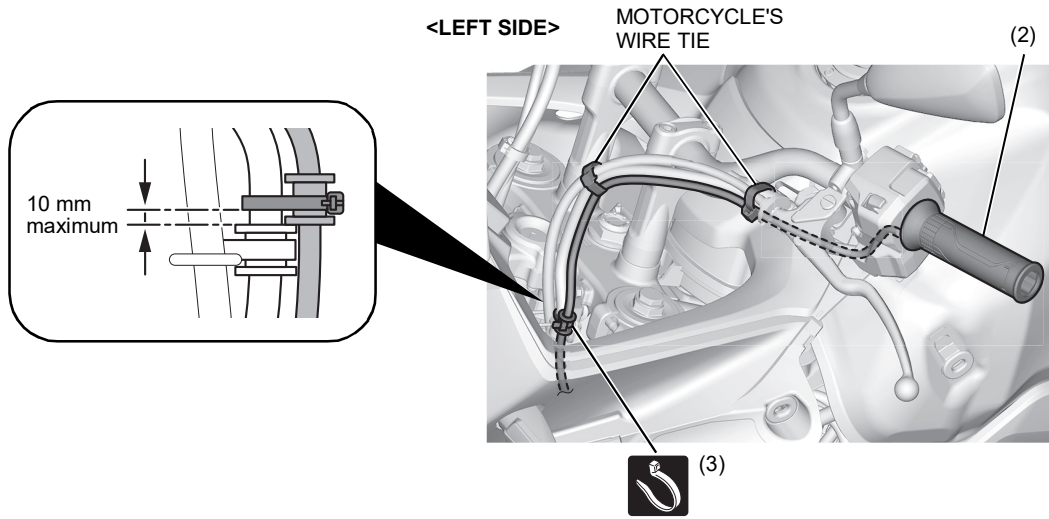

10. Route and connect the harness as shown.
- Cut off the excess ends of the wire ties (3), leaving a maximum of 5 mm.
 - Confirm that the grip heater harness does not contact the fuel tank.

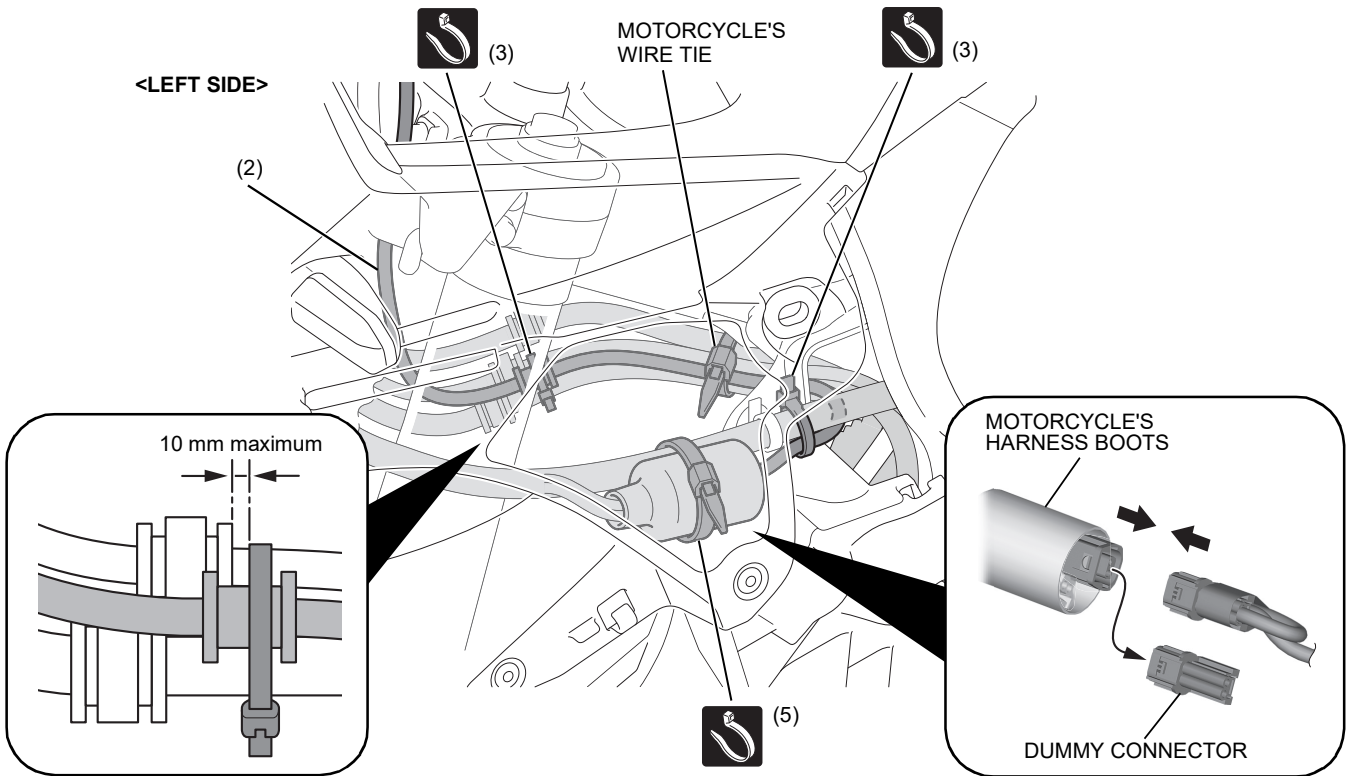

11. Install the motorcycle's parts in the reverse order of removal.
- Confirm that any harness is not caught or too tight.

SETTING INSTRUCTIONS

1. Open the seat and connect the SCS short connector (070MZ-0010300).
2. Turn the ignition switch ON with the engine stop switch RUN, but does not start the engine.
3. Push and hold the sel right switch to enter the setting mode.

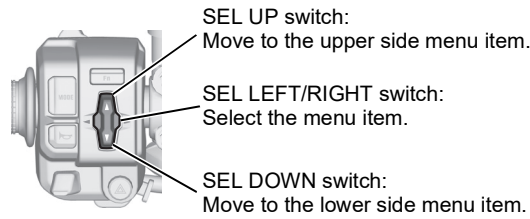

4. Select the SERVICE and EQUIPMENT.

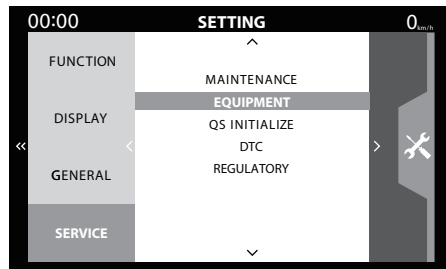

5. Set ON. (After removing the grip heater, set OFF.)

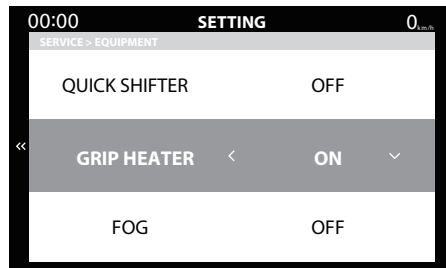

6. Turn the ignition switch OFF and remove the SCS short connector.

DEALER TROUBLESHOOTING

- Stop the engine and turn the ignition switch OFF when you check the parts and circuits other than those of the grip heaters.

Symptom	Check
<p>Grip heater status icon and grip heater level blinks.</p> <p>GRIP HEATER STATUS ICON</p> <p>GRIP HEATER LEVEL</p>	<p>If there is a malfunction, check the following.</p> <ol style="list-style-type: none"> 1. Body control system DTC: <ul style="list-style-type: none"> • Refer to the service manual for the motorcycle. 2. Grip heater resistance: <ul style="list-style-type: none"> Check for resistance between the terminals. ➔ Standard: <ul style="list-style-type: none"> Right: 1.9 ohms +/- 10% Left: 1.9 ohms +/- 10% If the resistance is out of specification, replace the grip heater. <p>The grip heaters and their circuits are OK, check the following.</p> <ol style="list-style-type: none"> 1. METER <ul style="list-style-type: none"> • Refer to the service manual for the motorcycle.